

SPL: 1m/1w in 76ft ENC (TL 302)
= 101.7 dB

DESCRIPTION

The Electro-Voice Model 30W woofer represents a dramatic development in the art of bass speaker design. Previously unattainable low-frequency performance results from the combination of a massive magnet structure, heavy duty, edgewise wound copper voice coil, and a rigid, polystyrene foam cone. A one-piece, diecast aluminum frame assures permanent component alignment while minimizing unit weight. As a result, the nine pound four ounce ceramic magnet in a twenty-three pound magnetic circuit accounts for over two-thirds of the total unit weight.

Reduced ear sensitivity in the low-frequency range requires high acoustic power to fully recreate the exciting and awe-inspiring qualities of instruments such as the pipe organ and bass drum. Because radiation resistance of a speaker at low frequencies is proportional to the cone radiating area, acoustic power output of a smaller woofer is far less for a given excursion. Even an excursion of one inch peak-to-peak with a typical twelve inch woofer delivers less than one acoustic watt at 40 Hz. The 30W, with a cone area of more than 500 square inches, provides the needed tremendous increase in radiation resistance and permits levels of performance in the extreme bass range never before achieved. Even at full power input, cone motion is within the linear range.

SPECIFICATIONS

Resonance:	15 Hz ±3 Hz
Impedance,	
Nominal:	8 ohms
Minimum:	5 ohms
D C Resistance:	4 ohms

Power Handling Capacity,

RMS:	60 watts
Pulsed:	150 watts

(See Figure 6)

Conversion Efficiency:

10%

EIA Sensitivity Rating:

54 dB

Recommended Crossover:

100 Hz

Voice Coil Diameter:

2½ inches

Magnet:

9 lb., 4 oz., ceramic

Dimensions:

29¾" dia., 13-13/32" depth behind wall

Net Weight:

34 pounds

Baffle Opening:

28¾ inches

Mounting:

6-3/8" holes equally spaced on 28-7/8" circle

ENCLOSURE DESIGN

As is the case with virtually any speaker, the enclosure determines the actual performance of the 30W. There are a number of enclosure approaches suitable for the 30W, each with certain special advantages, depending upon the intended use of the speaker.

All recommended enclosures are sealed (acoustic suspension) types. Ported enclosures (bass reflex) are neither necessary nor desirable for the 30W. Many factors can be varied to establish desired performance:

1. Enclosure volume
2. Damping material
3. System environment
4. Mass loading

ENCLOSURE VOLUME—Figure 1 shows the variation of

speaker resonance as the enclosure volume changes. Because it is the response curve which is of interest, rather than simply speaker resonance, Figure 2 shows representative response curves under anechoic or free-field conditions. Enclosure volumes of 22, 50 and 300 cubic feet yield speaker resonances of 40, 30 and 20 Hz., respectively.

As the enclosure gets smaller and the speaker resonance goes up, the speaker tends to become underdamped, yielding a rise in the response curve at resonance. An "optimum" response curve should be approximately 3 dB down at resonance. The change in damping is a very broad effect, with curves C and E representing an enclosure volume ratio of 13 to 1. By combining this effect with other variables which are controllable, the response of the completed system can closely match requirements.

ACOUSTIC DAMPING MATERIAL—An underdamped speaker can be compensated for through the use of acoustic resistance added inside the enclosure. Fiberglass builder's insulation, available in batts and rolls for use between joists and studs, is an inexpensive and effective damping material. Any paper or foil backing should be removed before inserting the fiberglass in the enclosure. Filling the enclosure until the fiberglass is slightly compressed will reduce the resonant frequency up to 10%, as well as slightly increasing the damping.

SYSTEM ENVIRONMENT—The space in which the speaker is used can affect its performance as much as any other factor involved. If the speaker is placed in an extremely large area, away from reflecting surfaces, its output will tend to be the same as anechoic or free-field conditions. If a speaker is placed against a solid wall, the junction of two walls, or in a corner formed by three walls, ($\frac{1}{2}$ space, $\frac{1}{4}$ space, and $\frac{1}{8}$ -space conditions) the low frequency energy is contained in a smaller angle of radiation, and the bass response will tend to rise. In an extremely large space approximating free-field, a response curve which is somewhat underdamped may provide the most satisfying performance. On the other hand, close reflecting surfaces will tend to boost low-frequency response, making an overdamped (rolled off) free-field curve more desirable. This can be achieved through the use of a larger enclosure and/or fiberglass damping.

MASS LOADING—When enclosure volume is severely limited, mass loading can be used to reduce the resonant frequency at a slight sacrifice of efficiency. This principle is employed in the Patrician 800 system, yielding a modest size enclosure with the 30W for home use. The simplest method of mass loading involves increasing the air load on the front of the speaker by facing the speaker toward a rigid surface, such as a wall (Figure 3).

As the speaker is brought closer to the wall, the effective

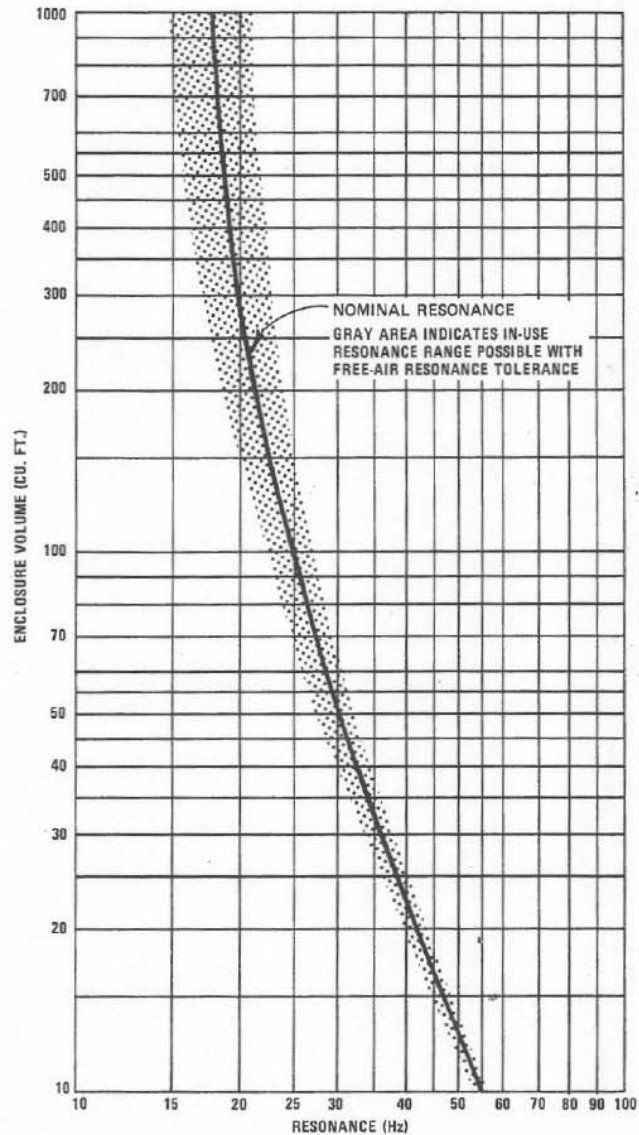

FIGURE 1 — Enclosure Volume vs Resonance

mass of air in front of the speaker increases, lowering the resonant frequency. Resonance can be lowered by as much as 25% with this technique. However, if cabinet space for a large enclosure is available, the conventional approach is preferable to mass loading.

ENCLOSURE CONSTRUCTION

Because any cabinet wall vibration is out of phase with the woofer cone, panel vibrations will cancel a portion of the woofer output. A concrete block enclosure is ideal, but far from practical! One-inch plywood walls, liberally braced with 2x4 sections, is a good compromise method of reducing panel vibration with manageable weight, cost, and ease of construction. Spacing of the 2x4 bracing on any panel should not exceed 24-inches in one direction.

Sixteen-inch spacing provides a more rigid panel and is more convenient to lay out, because most tape measures have sixteen-inch centers indicated for all stud spacing. All joints should be secured with a good grade of wood glue and coated nails, except for removable access panels. These should be secured with No. 8 x 2" woodscrews. Removable panels may be sealed with a closed-cell foam tape such as that used for weather-stripping, or with non-drying caulking compound.

Unlike most enclosures, there is no need to line the interior walls of the cabinet with fiberglass. The purpose of such a lining is to absorb standing waves inside the cabinet. However, the low frequencies of standing waves in 30W cabinets are not affected by a fiberglass lining on the cabinet walls. Adding fiberglass to the enclosure, as mentioned earlier, alters the response curve by lowering the system Q and also reduces the amplitude of standing waves inside the enclosure.

Mounting the 30W in a wall will probably necessitate the removal of more than 30 inches of one stud. Structural rigidity may be maintained through the use of a header and sill above and below the speaker as shown in Figure 4. For convenience, the 30W may be secured to a one-inch plywood mounting baffle which is then screwed to the wall studs and framing. Before proceeding with the mounting of the 30W in this way, however, it is extremely advisable to consult with a competent architect or builder.

CONNECTIONS

If the 30W is mounted in close proximity to the crossover and other components, No. 18 wire (such as ordinary lamp cord) is satisfactory. If the 30W is mounted some distance from the other components, No. 16 or larger wire should be used to keep the resistance losses as low as possible.

Both Model X1835 crossover (as used in the E-V Patrician 800) and Model X1020 crossover are designed specifically

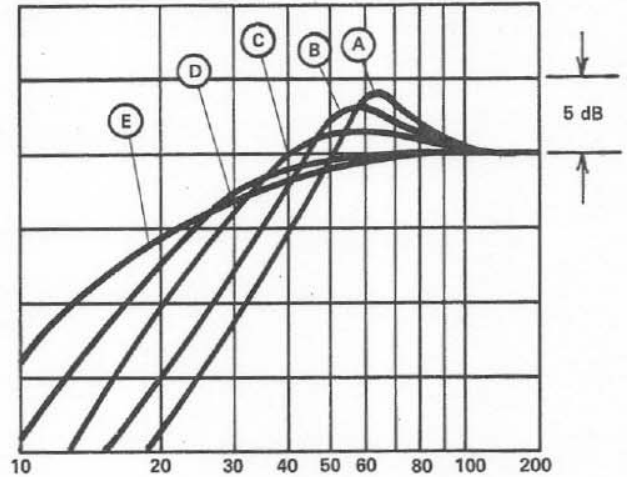

Curve	Volume (cu. ft.)	Resonance	Anechoic Response at Resonance	Damping
A	8.5	60 Hz	+4 dB	Under -
B	12.5	50 Hz	+2 dB	Under -
C	22	40 Hz	0 dB	Under -
D	50	30 Hz	-2.5 dB	"Optimum"
E	300	20 Hz	-6 dB	Over -

FIGURE 2 — Response Curves

for use with the 30W woofer. Model X1835 should be used with the Patrician components; the X1020 crossover allows the 30W to be added to an existing full-range system. The proper crossover frequency is 100 Hz.

In order to assure maximum bass response, a simple phase-reversing test should be made during installation. While playing a source with substantial sound below 100 Hz, such as an organ record, reverse the connections at the woofer. The connections with which bass response sounds

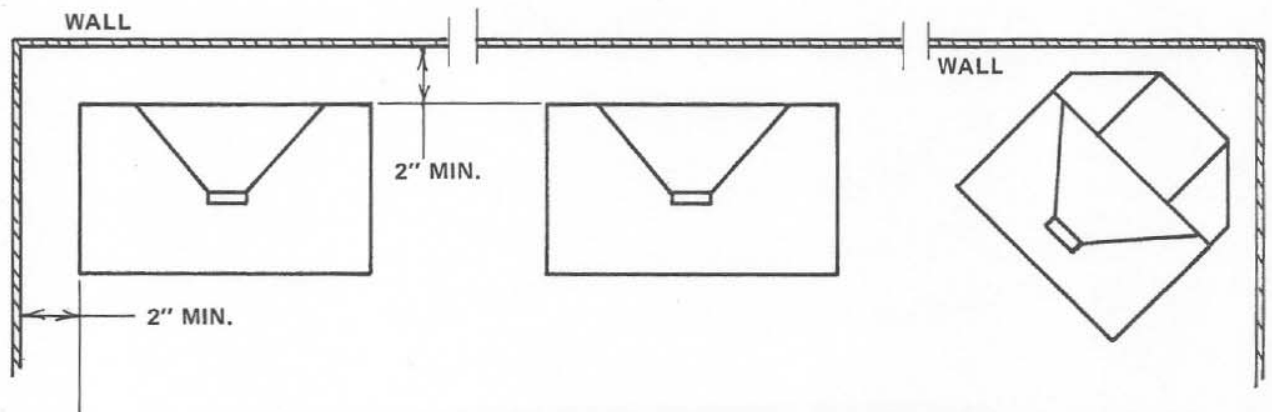

FIGURE 3 — Phase Loaded Enclosures

better is the proper connection. If there seems to be no difference when the change is made, then either connection is proper. This test is recommended because variations in speaker spacing and room acoustics may cause cancellation, rather than reinforcement, near the crossover frequency.

CUSTOMER SERVICE

The 30W is packed to provide protection well in excess of shipping requirements of the Interstate Commerce Commission. If shipping damage does occur, contact the carrier or the dealer from whom the unit was purchased and request inspection and instructions.

WARRANTY (Limited)

Electro-Voice high fidelity speakers, speaker systems, and accessories are guaranteed for five years from date of original purchase against malfunction due to defects in workmanship and materials. If such malfunction occurs, unit will be repaired or replaced (at our option) without charge for materials or labor if delivered prepaid to the proper Electro-Voice service facility. Unit will be returned prepaid. Warranty does not cover finish or appearance items or malfunction due to abuse or operation at other than specified conditions. Repair by other than Electro-Voice or its authorized service agencies will void this guarantee.

For correct shipping address, instructions on return of Electro-Voice products for repair, and locations of authorized service agencies, please write: Service Department, Electro-Voice, Inc., 600 Cecil Street, Buchanan, Michigan 49107 (Phone 616/695-6831).

Electro-Voice also maintains complete facilities for non-warranty service of E-V products.

Specifications subject to change without notice.

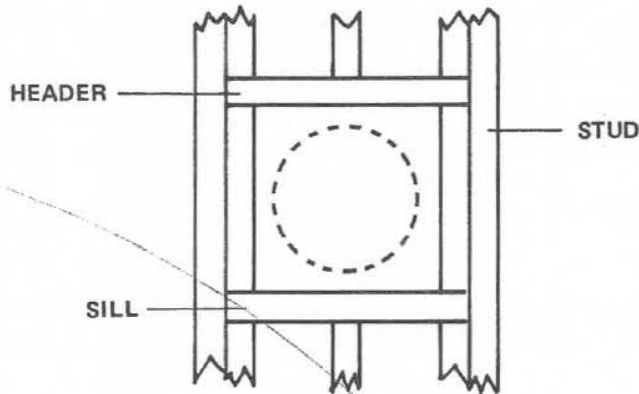

FIGURE 4 – Wall Mounting

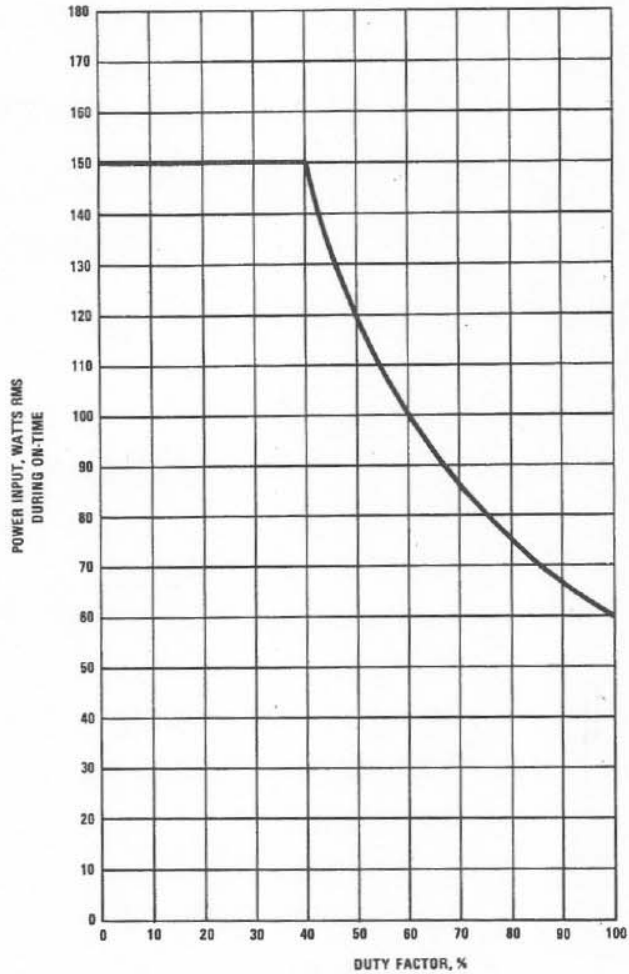

FIGURE 5 – Power Input vs Duty Factor